

UPON COMMENCEMENT OF  
INSTALLATION IT IS OF  
PARAMOUNT IMPORTANCE THAT  
THE STEP BY STEP GUIDE  
(INCLUDED) IS FOLLOWED  
COMPLETELY

UPON COMMENCEMENT OF  
INSTALLATION IT IS OF  
PARAMOUNT IMPORTANCE THAT  
THE STEP BY STEP GUIDE  
(INCLUDED) IS FOLLOWED  
COMPLETELY

### Gas Pressure Proving and Ventilation Interlock System

The **SafeAir (GP)** is a Ventilation Interlock and Gas Pressure Proving system. The system will ensure that any mechanical ventilation connected (supply or extract) is running before the gas can be used, when installed with gas sensors it will also monitor the atmosphere for CO and/or CO<sub>2</sub>. It will then continually monitor for fan operation.

The system will also ensure there are no gas leaks downstream of the control valve at switch on by way of a downstream integrity check, It continually checks that the incoming gas pressure is sufficient.

The system comprises of a mains powered panel capable of operating up to four sensors and a pressure sender unit. The sensors are pre-calibrated by Medem (UK) Ltd such that they only require to be addressed then connected to the panel and functionally tested. The ventilation is interlocked via a MEDEM current monitor model CM2M-K (separate) or mechanical air flow switches.

#### Detector Alarm levels

Type	Pre-Alarm	High Alarm
CO:	80ppm	100ppm
CO <sub>2</sub> :	2300ppm	5000ppm

Pre-alarm will display a warning message and tone (3beeps) every 10mins.

High-alarm will display a warning message, tone every one second and isolate the gas valve after 60seconds.

**Incoming gas pressure:** Min = 12 mbar, Max = 70mb.

**Fan failure:** Will cause the gas to isolate after 10 seconds.



#### Other points to note

The maximum cable length between a detector and the control panel should not exceed 100 metres, If the distance between the main panel and the detectors is greater than 20metres 1mm cable should be used on the +VE, 0v terminals.

**Pressure Sender Unit Mounting.** This has an inlet and an outlet port (1/4 inch NPT). The inlet must be connected to the inlet test point on the solenoid valve (see fitting kit page) and the outlet port after the solenoid valve typically using 8mm OD copper pipe. Use the appropriate Medem fitting kit to fit the control valve size. The pressure sender is connected to the control panel with low voltage two core cable using the terminal marked A & B. **NOTE: This is low voltage and should be segregated from mains wiring.**

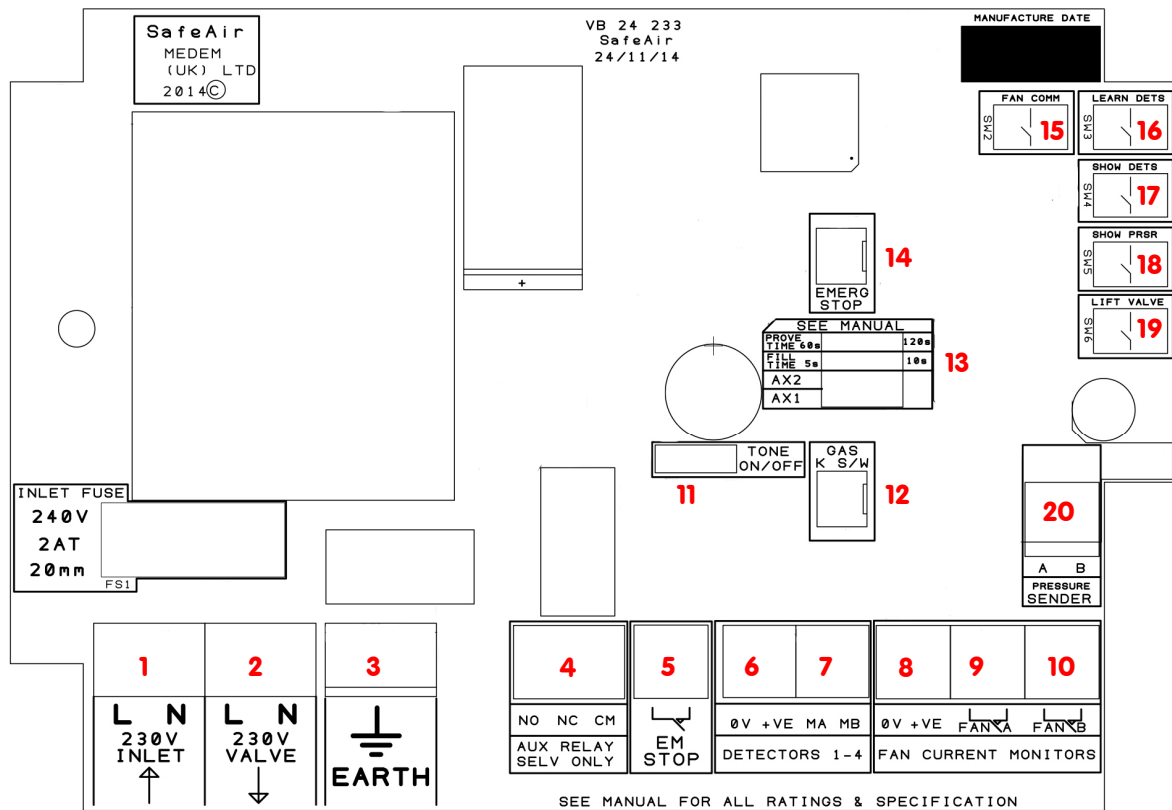

Connections to panel: marked on board.

1. Live & Neutral 230 volts supply from 3amp switched fuse spur
2. 230 volts out to gas solenoid valve
3. Earth connection terminals
4. BMS to indicate, high alarm, gas on, EM stop, low alarm. (Using No13 AX1 & 2 )
  - 00 = Gas On
  - 10 = Fan Fault
  - 01 = EM Stop & High Alarm
  - 11 = Unused
5. Remote emergency stop buttons SELV, connect in series multiple buttons (requires a N/C circuit)
6. Power connections for detectors, Methane, LPG, CO, CO2, Oxygen, Temperature
7. Comms connections for detectors, Methane, LPG, CO, CO2, Oxygen, Temperature
8. 12 volt power for current monitor (CM2M-K)
9. Fan A interlock for current monitor (CM2M-K) or PD switches.
10. Fan B interlock for current monitor (CM2M-K) or PD switches.
11. Jumper link to disable audible alarm sounder.
12. Header socket for front panel key switch.
13. Fill & prove time for gas pressure proving & AUX relay settings (see No4).
14. Header socket for front panel Emergency stop button.
15. Fan comm button, enables commissioning of the gas supply without fans running.
16. Learn detectors button, press once only when all detectors are connected and powered
17. View detectors
18. Display gas pressures on the LCD screen
19. Lift valve button, opens the gas valve only whilst the button is continuously pressed, for commissioning purposes.
20. Pressure sender unit SELV and comm's both through "A" & "B" terminals (2 wire) MUST BE FITTED

### Interlocking ventilation via current monitoring

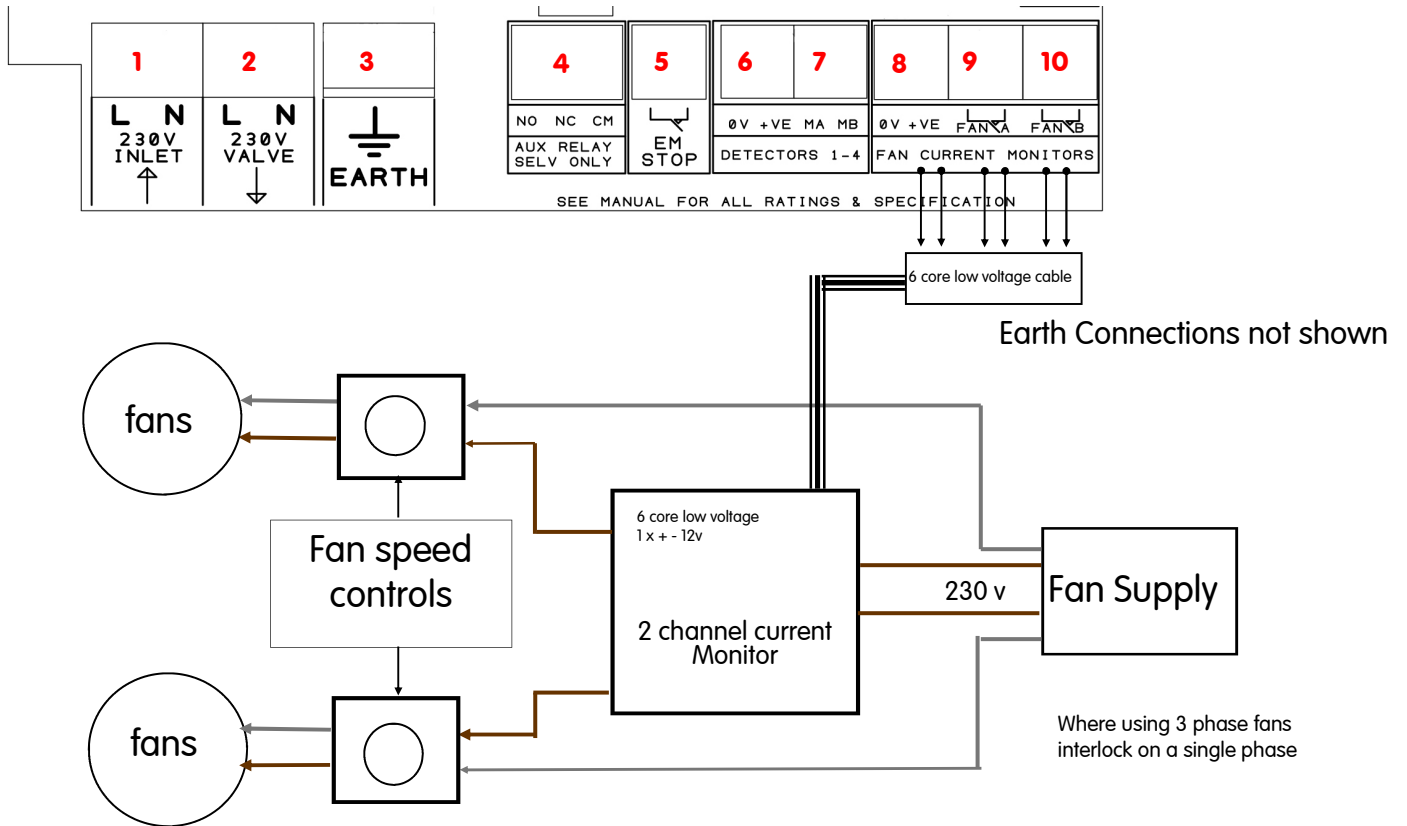

### Installing gas detectors

Gas detectors are wired via a four core low voltage cable into terminals marked 6 & 7. The detectors must have their "address id selector switch" set to the addresses 1-4.

Once connected and addressed the system must be "taught" which detector types are on which address. This is done by pressing button marked 16. The system will beep to confirm the action.

Pressing No 17 will display detector addresses 1 & 2, pressing 17 & 18 together will display addresses 3 & 4.

### Detector Fault DXX Lost Comms

If the system displays a message "Detector Fault DXX Lost Comms" the system is informing you that a detector which has been previously "learnt" to address DXX is no longer communicating. This could be because the detector has had its address changed or has been removed. In which case "re-learning" using button 17 will correct the addressing.

If the detector is present, but not being seen by the system on its address channel, then check the wiring between the main control panel and detector.

